

NOTES

- 1 MODEL SHOWN IS 12' VEHICLE CLEARANCE HEIGHT WITH 17 PELTS BRUSH OF 48" LENGTH. REFER TO ELP DRAWING FOR DETAILED CONFIGURATION OF SPECIFIC JOB
- 2 2 GREASE LINES (P/N 964-0000) ARE REQUIRED.
- 3 PLUMBING, ELECTRICAL, PNEUMATIC AND ROUTING: REFER TO ELP DRAWING OR CUSTOM MANUFACTURING DRAWING OF SPECIFIC JOB ORDER FOR MORE DETAIL.

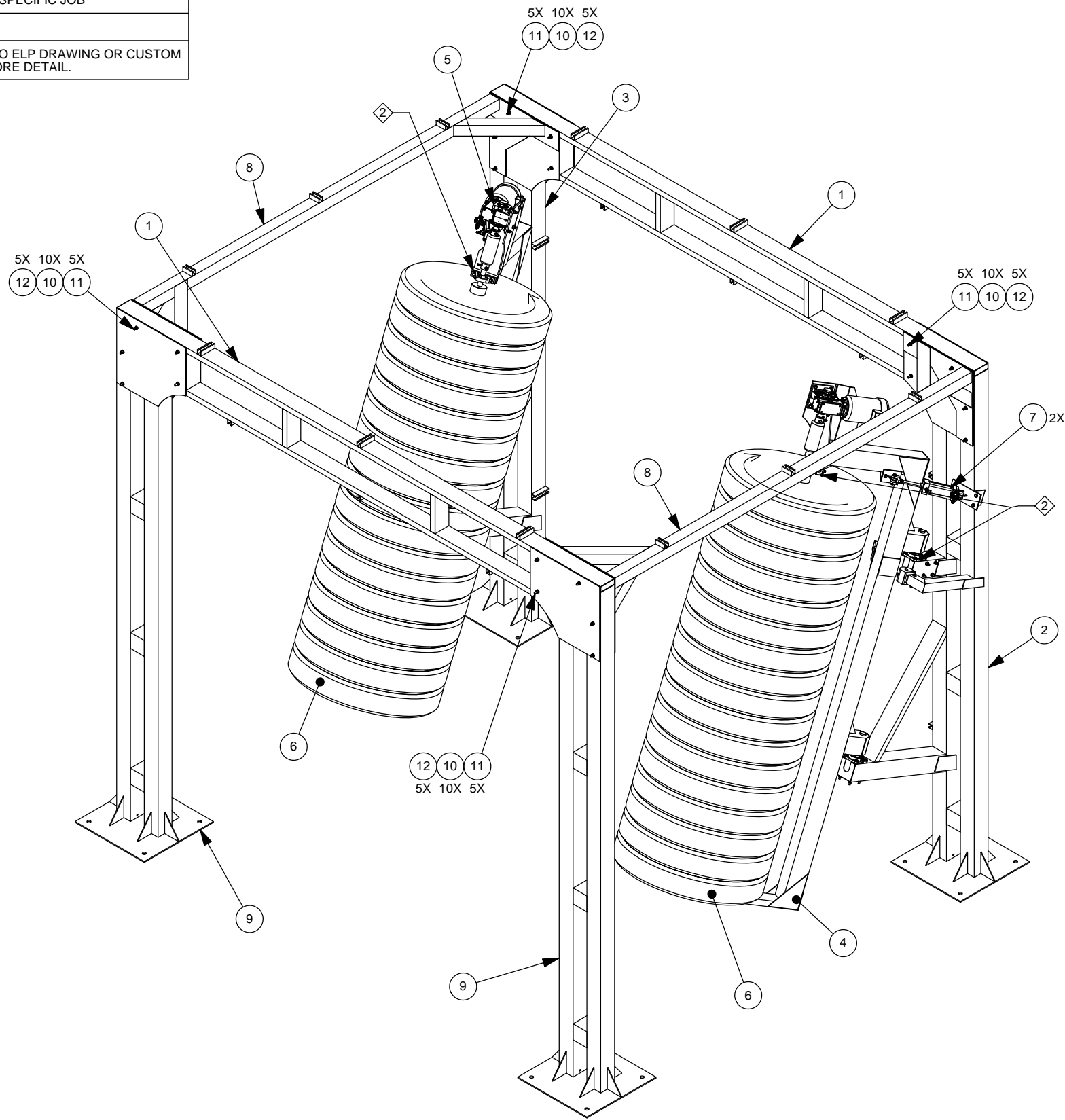

ITEM NO.	PART NUMBER	DESCRIPTION	QTY.
1	900-5200	TRAIN WASH BASIC BULKHEAD, S.S.	2
2	960-0016	TRAIN WASH SLANTED SIDE BRUSH LEG ASSEMBLY, DRIVER SIDE, S.S.	1
3	960-0017	TRAIN WASH SLANTED SIDE BRUSH LEG ASSEMBLY, PASSENGER SIDE, S.S.	1
4	960-0018	TRAIN WASH SLANTED SIDE BRUSH ARM ASSEMBLY, DRIVER SIDE, S.S.	1
5	960-0019	TRAIN WASH SLANTED SIDE BRUSH ARM ASSEMBLY, PASSENGER SIDE, S.S.	1
6	960-0020	TRAIN WASH SIDE BRUSH, FIBER BRUSH ASSEMBLY	2
7	960-0015	TRAIN WASH SIDE BRUSH AIR CYLINDER ASSEMBLY	2
8	900-5204-S	TRAIN WASH SIDE FRAME OF SLANTED SIDE BRUSH, S.S.	2
9	900-5201	TRAIN WASH BASIC LEG, S.S.	2
10	870-1400	FLAT WASHER, 1/2", SAE, 18-8 STAINLESS STEEL	40
11	820-1655	HEX CAP SCREW, 1/2"-13 X 8" LG., 18-8 STAINLESS STEEL	20
12	840-2000	LOCK NUT, 1/2"-13, 18-8 STAINLESS STEEL	20

<p>N/S CORPORATION</p> <p>THE INFORMATION CONTAINED IN THIS DRAWING IS THE SOLE PROPERTY OF N/S CORPORATION. ANY REPRODUCTION IN PART OR WHOLE WITHOUT THE WRITTEN PERMISSION OF N/S CORPORATION IS PROHIBITED.</p>	<p>DIMENSION TOLERANCES (INCH): FRACTIONAL ± 1/16" TWO PLACE DECIMAL ± 0.03 THREE PLACE DECIMAL ± 0.005</p> <p>ANGULAR TOLERANCES (DEGREE): INTEGER NUMBER ± 1° ONE PLACE DECIMAL ± 0.2°</p>	SCALE	1:20	DRAWN BY	YS	<p>PART NAME</p> <p>TRAIN WASH SLANTED SIDE BRUSH, S.S., STAND ALONE</p>
		CHECKED BY		APPROVED BY		
		INITIAL RELEASE DATE		INITIAL RELEASE ERF	0660	
		PART NUMBER		TW-SSB-S		
						SHEET 1 OF 1