

NOTES

- 1 MODEL SHOWN IS 12' VEHICLE CLEARANCE HEIGHT WITH 17 PELTS BRUSH OF 48" LENGTH. REFER TO ELP DRAWING FOR DETAILED CONFIGURATION OF SPECIFIC JOB
- 2 2 GREASE LINES (P/N 964-0000) ARE REQUIRED.
- 3 PLUMBING, ELECTRICAL, PNEUMATIC AND ROUTING: REFER TO ELP DRAWING OR CUSTOM MANUFACTURING DRAWING OF SPECIFIC JOB ORDER FOR MORE DETAIL.

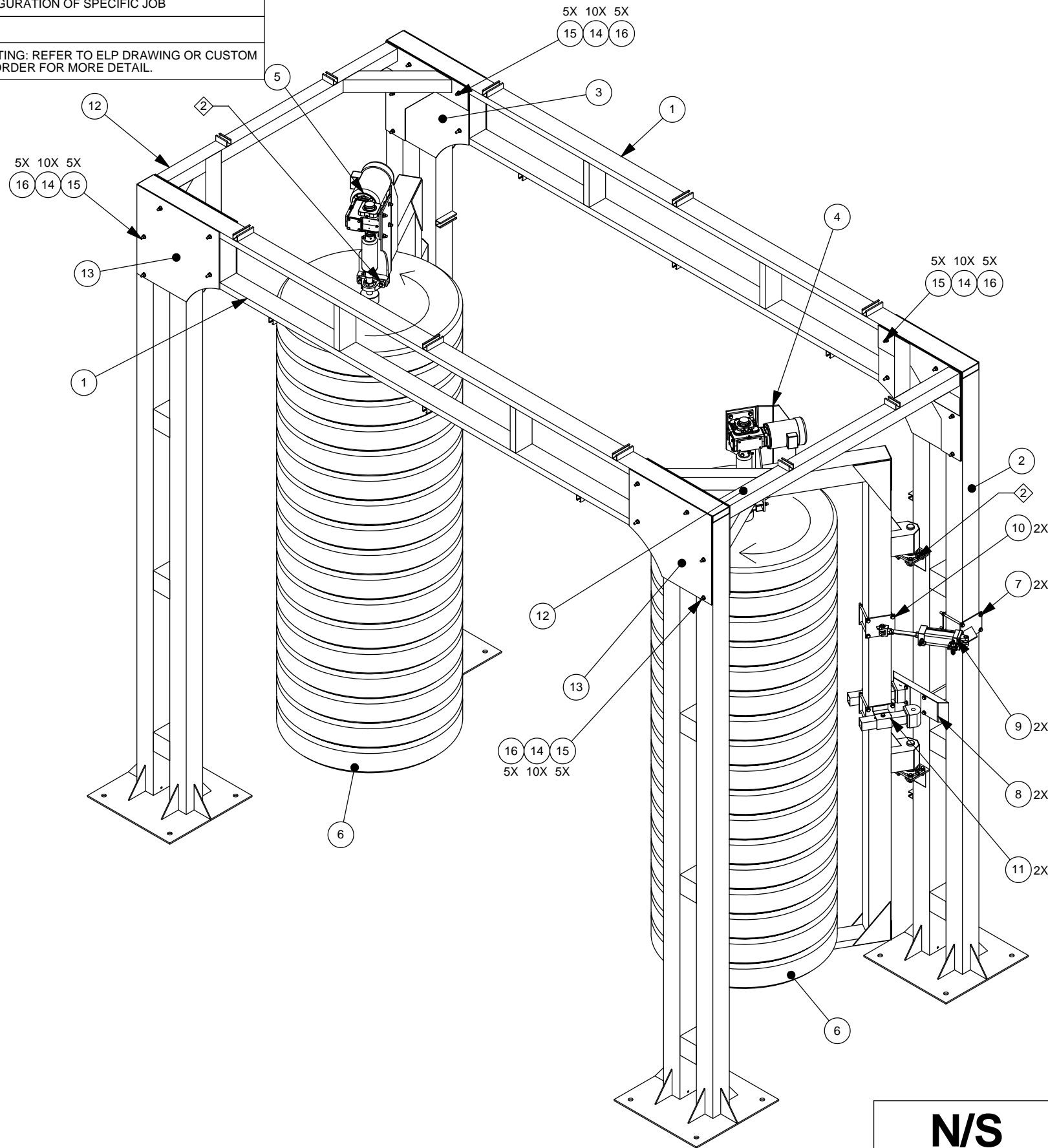

ITEM NO.	PART NUMBER	DESCRIPTION	QTY.
1	900-5200	TRAIN WASH BASIC BULKHEAD, S.S.	2
2	960-0028	TRAIN WASH VERTICAL SIDE BRUSH DRIVER SIDE LEG ASSEMBLY, S.S.	1
3	960-0029	TRAIN WASH VERTICAL SIDE BRUSH PASSENGER SIDE LEG ASSEMBLY, S.S.	1
4	960-0030	TRAIN WASH VERTICAL SIDE BRUSH DRIVER SIDE ARM ASSEMBLY, S.S.	1
5	960-0031	TRAIN WASH VERTICAL SIDE BRUSH PASSENGER SIDE ARM ASSEMBLY, S.S.	1
6	960-0020	TRAIN WASH SIDE BRUSH, FIBER BRUSH ASSEMBLY	2
7	960-0027	TRAIN WASH VERTICAL SIDE BRUSH AIR CYLINDER LEG MOUNTING BRACKET ASSEMBLY, S.S.	2
8	960-0025	TRAIN WASH VERTICAL SIDE BRUSH BUMPER STOP ASSEMBLY, S.S.	2
9	960-0015	TRAIN WASH SIDE BRUSH AIR CYLINDER ASSEMBLY	2
10	960-0026	TRAIN WASH VERTICAL SIDE BRUSH AIR CYLINDER ARM MOUNTING BRACKET ASSEMBLY, S.S.	2
11	960-0024	TRAIN WASH VERTICAL SIDE BRUSH BUMPER MOUNTING ASSEMBLY, S.S.	2
12	900-5204-V	TRAIN WASH SIDE FRAME OF VERTICAL SIDE BRUSH, S.S.	2
13	900-5201	TRAIN WASH BASIC LEG, S.S.	2
14	870-1400	FLAT WASHER, 1/2", SAE, 18-8 STAINLESS STEEL	40
15	820-1655	HEX CAP SCREW, 1/2"-13 X 8" LG., 18-8 STAINLESS STEEL	20
16	840-2000	LOCK NUT, 1/2"-13, 18-8 STAINLESS STEEL	20

<p>N/S CORPORATION</p> <p>THE INFORMATION CONTAINED IN THIS DRAWING IS THE SOLE PROPERTY OF N/S CORPORATION. ANY REPRODUCTION IN PART OR WHOLE WITHOUT THE WRITTEN PERMISSION OF N/S CORPORATION IS PROHIBITED.</p>		SCALE 1:16	DRAWN BY YS	PART NAME TRAIN WASH VERTICAL SIDE BRUSH, S.S., STAND ALONE		
	DIMENSION TOLERANCES (INCH): FRACTIONAL ± 1/16" TWO PLACE DECIMAL ± 0.03 THREE PLACE DECIMAL ± 0.005	CHECKED BY	APPROVED BY	PART NUMBER TW-VSB-S		
	ANGULAR TOLERANCES (DEGREE): INTEGER NUMBER ± 1° ONE PLACE DECIMAL ± 0.2°	INITIAL RELEASE DATE	INITIAL RELEASE ER# 0660			
				SHEET 1 OF 1		